

User manual

Level Van

EN

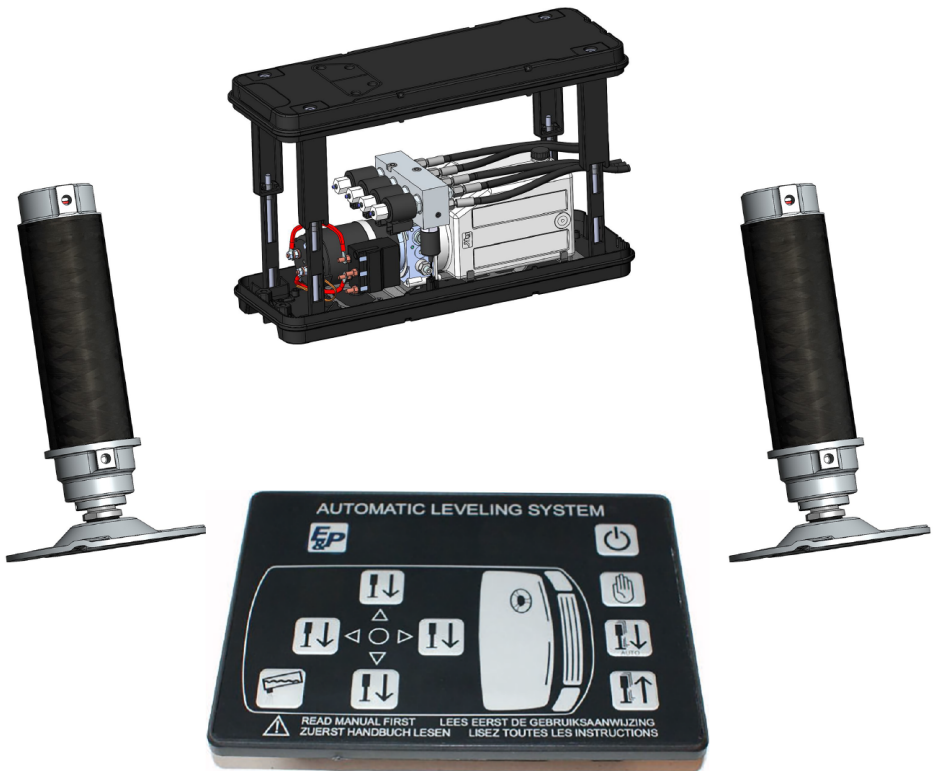

Contents

Preface	6
Copyright statement.....	6
Limited warranty.....	6
Declaration of conformity	7
About this document	8
Contact information.....	8
Document details.....	8
About the system in this document.....	8
Terminology.....	8
How to use this document.....	8
Purpose of this document.....	8
Revision history.....	8
Related documents.....	8
Conventions.....	9
Illustrations.....	9
Units of measurement.....	9
Original language.....	9
Safety symbols used in this document.....	9
Safety	10
Intended use.....	10
Possible misuse.....	10
Approved personnel.....	10
Approved installation technician.....	10
Approved operator.....	10
Safety instructions.....	10
General safety instructions.....	10
Specific safety instructions.....	10
Disposal.....	10
Description	12
Description of the system.....	12
Overview of the parts of the system.....	13
Overview of the hydraulic pump.....	14
Overview of the control panel.....	15
Operation	17
Level the vehicle.....	17
Automatic leveling.....	17
Manual leveling.....	18
Calibrate the leveling position.....	21
Retract the jacks.....	23
Automatic.....	23
Manual.....	24
Use the inclination function.....	25

Emergency operation.....	26
Maintenance.....	28
Maintenance Schedule.....	28
Preventive maintenance.....	28
Troubleshooting.....	29
General troubleshooting procedure.....	29
Error descriptions.....	29
Error mode.....	31
Troubleshooting table.....	31
Technical specifications.....	32
Specifications of the hydraulic pump.....	32

PREFACE

Copyright statement

This document is protected by copyright, all rights are reserved. Under copyright laws, no part of this document may be copied, photocopied, reproduced, translated, or made into an electronic medium without written permission from E&P Hydraulics.

Limited warranty

- Read this document and understand the contents of this document fully, before you use the Level Van. E&P Hydraulics will not be liable for any direct, indirect, consequential or incidental damage that comes forth from the misuse of the product or not obeying the contents of this document.
- E&P Hydraulics reserves the right to change parts of the product and to make changes to the product and its document without prior notice given to any party, including the end user.
- E&P Hydraulics offers a 2-year warranty for the Level Van on the material.
- The Level Van comes with a registration number stated on the product. Make sure this number remains legible. This registration number is necessary when the servicing of the product must be done.
- The manufacturer's warranty is only valid if the product is purchased from an authorized E&P Hydraulics dealer.
- The guarantee expires if installation, modification, maintenance or repairs are made to the product or its components by a non E&P Hydraulics authorized dealer or installer.
- An appeal on the manufacturer's limited factory warranty is only eligible for adoption if an official E&P Hydraulics dealer or installer determines the material and/or manufacturing defect within the warranty period and the appeal to guarantee is done within two weeks after this determination.
- Repair and/or restoration work must not be started before the warranty claim is assigned by E&P Hydraulics and the planned repair is approved by E&P Hydraulics.
- A warranty claim must be made promptly upon discovery of the problem to E&P Hydraulics. Should this not be the case, E&P Hydraulics can reject the warranty claim, especially if the problem could be exacerbated by the late reporting, this is at the sole discretion of E&P Hydraulics.
- E&P Hydraulics is not liable for any form of physical, financial or physical direct or consequential damage caused by (parts of) the product, except where the damage concerns the product itself, as per the regulations provided in Directive 85/374/EEC.
- Excluded are (parts of) products which are used for commercial business, in the sale or on offer, or sold with defects, and/or products where the E&P Hydraulics identification signs have been deleted, removed or made unreadable.

DECLARATION OF CONFORMITY

EC DECLARATION OF CONFORMITY

We hereby declare that this product, in the version placed on the market by us, complies with the requirements of the harmonised EU Directives, EU safety standards and the product-specific standards.

Product	Type	Serial number
E&P hydraulic levelling system	LevelVan	4101440

Manufacturer

E&P Hydraulics
Haverstraat 143
2153 GD Nieuw Vennep
Netherlands

Harmonised standards:

EN ISO 12100
EN 50498
EN 300220
EN 300328

Directives

2014/30/EU
2014/53/EU

15.05.2024, Nieuw Vennep
Netherlands

Duly authorised person

E&P Hydraulics B.V.
Haverstraat 143
2153 GD Nieuw-Vennep
Netherlands

Roland Dejong
(CCO) chief customer officer
E&P Hydraulics B.V.

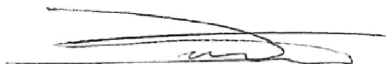

ABOUT THIS DOCUMENT

Contact information

Manufacturer	
Name	E&P Hydraulics
Address	Haverstraat 143, 2153 GD, Nieuw-Vennep, The Netherlands
Phone	+31 (0)25 2626151
E-mail	info@ep-hydraulics.com
Website	www.ep-hydraulics.com

Document details

About the system in this document

The Level Van described in this document is a system that automatically or manually levels motorhomes.

Terminology

This document refers to the Level Van as 'system'.

How to use this document

1. Read this document to use the system correctly.
2. This document is a permanent component of the system, and it must stay with the module during the full life cycle of the module.

Purpose of this document

This document gives the description of the system and the operation of the control panel.

Revision history

Date	Revision number	Reason
April 2024	1.0	First published version

Related documents

Document name	Document code	Target group
Installation instructions hydraulic leveling support system	1808283_b	Approved installation technician
Operating instructions hydraulic Level System	4100894_a	Approved operator

Conventions

Illustrations

The illustrations are for reference only.

Differences between the illustrations and the system are possible but do not have an effect on the correct use of this document.



Units of measurement

In this manual SI units of measurement (metric system) as well as imperial units of measurement are used. The imperial units are between parentheses () or in separate columns in tables.

Original language

The original language of this document is American-English. All other available language versions of this document are translations of the original version.

Safety symbols used in this document

Symbol	Function	Description
	Warning	If you do not obey the instructions, death, serious personal injury or damage to the system can occur.
	Caution	If you do not obey the instructions, damage to the system is possible.
	Note	To give additional information.

SAFETY

Intended use

- The E&P Hydraulics system is intended to automatically or manually level motorhomes.
- Do not use the system for any other purpose than described in this document.

Possible misuse

Do not use the system to do maintenance under the vehicle.

Approved personnel

Approved installation technician

The term approved installation technician is specified here as the person who fully knows the system and its safe operation. The approved installation technician obeys all safety regulations. To install the system, E&P Hydraulics gives a training to the approved installation technician. Only after this training the installation technician is allowed to install the system.

Approved operator

The term approved operator is specified here as the end user of the system. The approved operator obeys all safety regulations.

Safety instructions

General safety instructions

- Read the document before you operate the system.
- Only use the E&P Hydraulics system as intended.
- Make sure that the leveling system is installed by an approved installation technician that received training by E&P Hydraulics.
- Only approved installation technicians are permitted to repair the system.

Specific safety instructions

- Do not use the system to do other work below the vehicle, such as change the tires, do maintenance, or apply snow chains.
- Be careful with fluids from the system to prevent injury to the skin and eyes.
- Do not lift the vehicle too high. The vehicle can become unstable.
- Park the vehicle on a solid, non-slippery surface, and make sure that the surface is as level as possible. The location must be free of holes, waste and objects.
- Use a support plate or an E&P Hydraulics footplate cover below each jack to divide the weight if the vehicle is parked on very soft soil.
- Make sure that the vehicle is level after using the system. Walk around the vehicle to make sure that all hydraulic jacks are on the ground.
- Do not spray the system with direct water jets, e.g. high-pressure cleaners.

Disposal

When you discard of the system or its parts:

-
- Obey local regulations;
 - Obey instructions to sort the waste of the module;
 - Obey safety and health instructions with regard to the module.

Prevent pollution. Be friendly to the environment.

DESCRIPTION

Description of the system

The Level Van is a hydraulic system used to automatically level a vehicle.

The E&P Hydraulics system consists of:

- A hydraulic pump that pumps hydraulic oil through a system of hydraulic hoses and four hydraulic jacks with foot plates that make the vehicle stable.
- A main unit that is installed on a central location in the vehicle.
- Hoses and electric wirings.
- Individual brackets adapted to the vehicle.
- An optional Weight Measuring Module.

Overview of the parts of the system

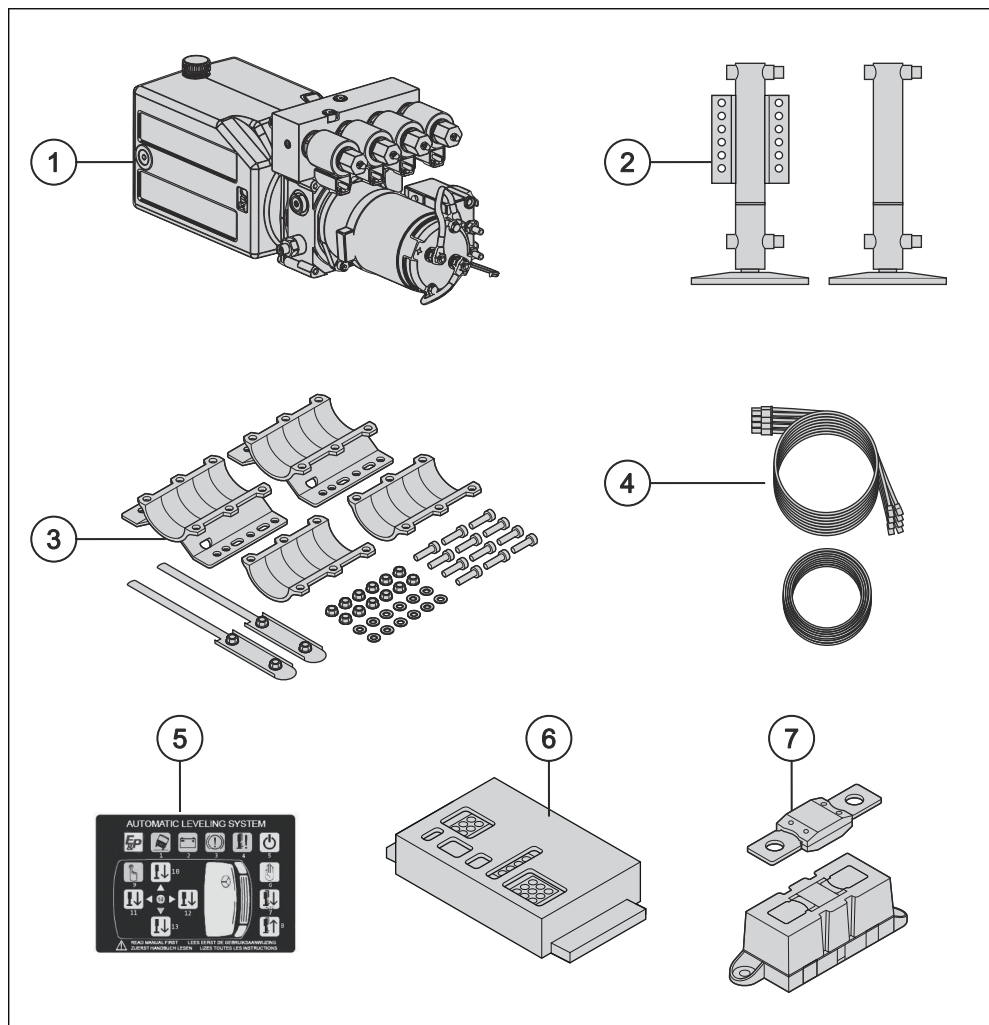

- 1 Hydraulic pump
- 2 Hydraulic jacks
- 3 Individual brackets adapted to the vehicle
- 4 Hoses and electric wirings

- 5 Control panel
- 6 Main unit
- 7 Fuse and fuse holder

Overview of the hydraulic pump

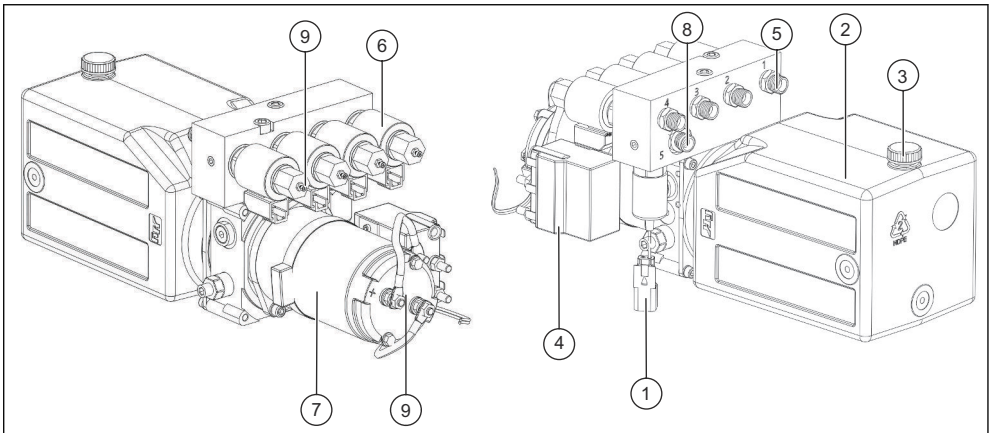





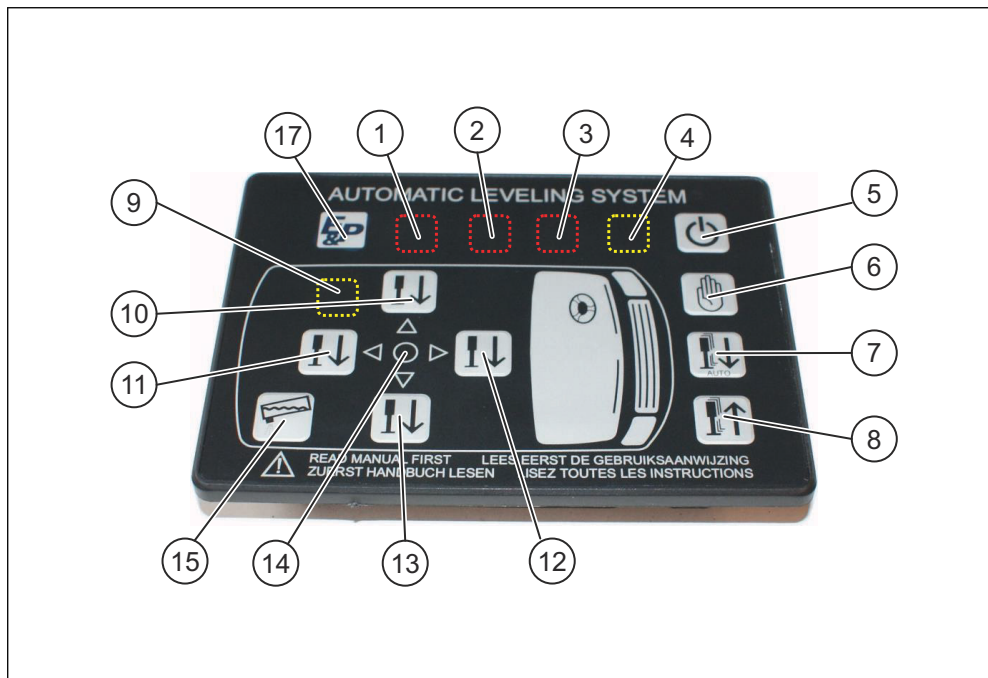



- 1 Pressure switch
- 2 Oil reservoir
- 3 Filler cap
- 4 Relay
- 5 Supply connection to the hydraulic jack (4x)
- 6 Valve (4x)
- 7 Electric motor
- 8 Return connection
- 9 Screws and hexagon socket for emergency operation. Refer to [Emergency operation](#)

Overview of the control panel



	Icon	Name	Function	Description
(1)		Slope too steep	LED	The vehicle can not be leveled because the surface is not sufficiently flat. Move the vehicle to a flatter surface or use the manual mode.
(2)		Battery low voltage	LED	The vehicle battery is empty or the voltage is too low.
(3)		Engage hand brake	LED	The handbrake is disengaged. Engage the handbrake.
(4)		Jacks not retracted	LED	One or more jacks are extended or not fully retracted.

	Icon	Name	Function	Description
(5)		ON / OFF	Button	To turn the level system on or off.
(6)		Manual mode	Button	To set the level system into manual mode.
(7)		Automatic mode	Button	To set the level system into automatic mode.
(8)		Retract all jacks	Button	To automatically retract the jacks.
(9)		Manual mode	LED	The vehicle can be moved to the correct level manually.
(10)		Left side	Button	To operate the extension of the left jacks during the manual leveling procedure.
(11)		Rear side	Button	To operate the extension of the rear jacks during the manual leveling procedure.
(12)		Front side	Button	To operate the extension of the front jacks during the manual leveling procedure.
(13)		Right side	Button	To operate the extension of the right jacks during the manual leveling procedure.
(14)		Level	LED	The vehicle can be moved to the correct level.
(15)		Inclination	Button	To start the inclination function to empty the dirty-water tank.
(17)		E&P Logo	LED	The level system is ON.

OPERATION

Level the vehicle

Read the safety instructions before you start the leveling procedure. Refer to [Safety instructions](#).

Automatic leveling

Make sure that the ignition of the vehicle is set to ON.

Make sure that the handbrake is engaged.

1. Push on the *ON / OFF* button (5) to turn the level system ON.

The E&P logo LED (17) lights up.



Note: The leveling can not be done if the surface is not sufficiently flat (1), the battery level is too low (2) or if the handbrake is disengaged (3).

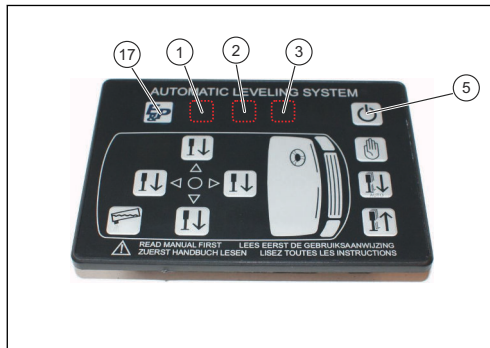

2. Push the *Automatic mode* button (7) to start the automatic leveling procedure.

✓ The automatic leveling procedure starts.

The Level LED (14) lights up GREEN when the leveling procedure is completed.



3. Push the *ON / OFF* button (5) to turn the level system OFF.



Manual leveling

Make sure that the ignition of the vehicle is set to ON.

Make sure that the handbrake is engaged.



Caution: If necessary, use support plates below the footplates of the jacks on the lower side to compensate large height differences.

The manual leveling function is used when the vehicle cannot be leveled with automatic leveling because the surface is not sufficiently flat. With manual leveling it is also possible to change the position of the vehicle, for example, put the head side of the bed higher than the feet side to make your sleeping comfort better.

1. Push on the *ON / OFF* button (5) to turn the level system ON.

✓ The E&P logo LED (17) lights up.



Note: The leveling can not be done if the surface is not sufficiently flat (1), the battery level is too low (2) or if the handbrake is disengaged (3).

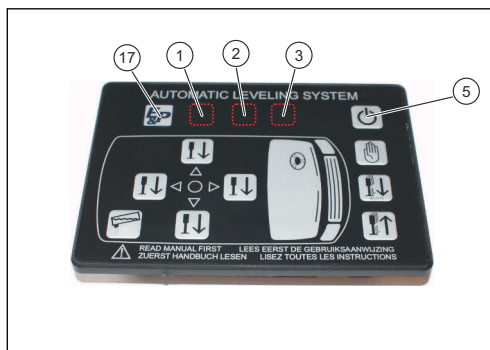

2. Push the *Manual mode* button (6).

✓ The Manual mode LED (9) lights up. You can start the manual leveling procedure.



3.



Caution: Always level the vehicle on the front side first.

Push the *Front side* button (12) and hold it down until the front jacks lift the vehicle approximately 3 centimeters on the front side.

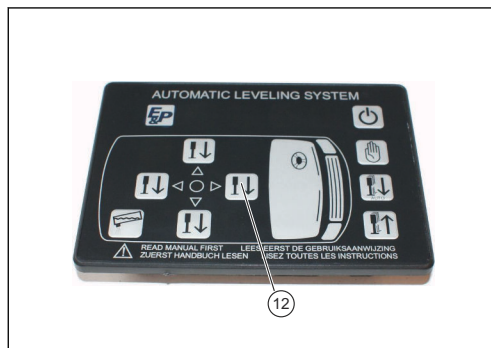

4. Push the *Rear side* button (11) and hold it down until the rear jacks lift the vehicle approximately 3 centimeters on the rear side.



5. Make the vehicle level.

The position of the yellow arrow of the Level LED (14) shows which side of the vehicle you must level.

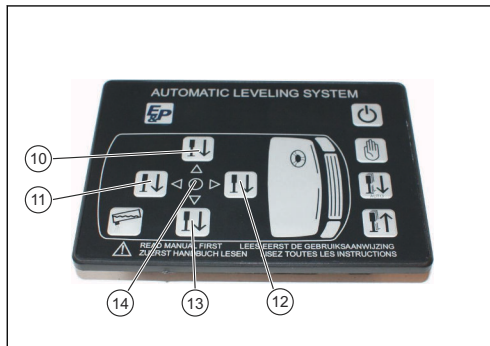

Caution: When two yellow arrows light up, level the vehicle gradually. Do not first fully level one side until the level system stops and then fully level the other side. Move one side a small distance and then move the other side a small distance. Continue to move the two sides until the vehicle is level.

**LED****Action**

If the yellow arrow points to the front side of the vehicle: push the *Front side* button (12) and hold it down until the system automatically stops leveling.



If the yellow arrow points to the rear side of the vehicle: push the *Rear side* button (11) and hold it down until the system automatically stops leveling.



If the yellow arrow points to the left side of the vehicle: push the *Left side* button (10) and hold it down until the system automatically stops leveling.



If the yellow arrow points to the right side of the vehicle: push the *Right side* button (13) and hold it down until the system automatically stops leveling.



If the middle of the Level LED (14) lights up in GREEN, the vehicle is level.

6. Push the *ON/OFF* button (5) to turn the level system OFF



Calibrate the leveling position



Note: Your dealer/installer did the calibration procedure. It is not necessary for you to do this procedure. This procedure is for servicing and repair if the system fails.

A zero point must be set to level the vehicle automatically or manually. The zero point is the level to which the hydraulic leveling system returns in automatic mode. If the zero point is not calibrated, it is not possible to level the vehicle.

1. Put a spirit level in the center of the vehicle.
2. Use the spirit level to make the vehicle level with the manual leveling procedure. Refer to [Manual leveling](#).
3. Make sure the level system is OFF.
4. Push on the *ON/OFF* button (5) to turn the level system ON.
✓ The E&P logo LED (17) lights up.



5. Push the *Front side* button (12) five times.



6. Push the *Rear side* button (11) five times.
 ✓ All LEDs on the control panel light up. The vehicle is in zero mode.



7. Push the *Retract all jacks* button (8) three times.
 ✓ The zero point is set.



- Push on the *ON / OFF* button (5) to turn the level system OFF.



Retract the jacks

Do the automatic or manual procedure to retract the jacks.



Note: If the system is connected as such, the jacks are also retracted when the parking brake is disengaged or when the ignition is set to ON.

Automatic

- Push on the *ON / OFF* button (5) to turn the level system ON.
 ✓ The E&P logo LED (17) lights up.



2. Push the *Retract all jacks* button (8) to start the automatic retraction of the jacks.
 ✓ When the retraction of the jacks is completed, the *Jacks not retracted* LED (4) goes off and the hydraulic pump stops.



3. Push the *ON / OFF* button (5) to turn the level system OFF



Manual

1. Push on the *ON / OFF* button (5) to turn the level system ON.
 ✓ The *E&P* logo LED (17) lights up.



2. Push the *Retract all jacks* button (8) and hold it down until all jacks are fully retracted.

✓ When the retraction of the jacks is completed, the *Jacks not retracted* LED (4) goes off and the hydraulic pump stops.



3. Push the *ON / OFF* button (5) to turn the level system OFF



Use the inclination function

Use the inclination function to empty the dirty-water tank. The dirty water flows quickly from the tank so that the soil debris is also removed.



Note: The outlet of the tank must be mounted on the left side or the right side of the vehicle, not in the middle.

1. Push on the *ON / OFF* button (5) to turn the level system ON.
✓ The E&P logo LED (17) lights up.



2. Push the *Inclination* button (15).
✓ The vehicle moves to the position as programmed by your dealer.



Note: There is a maximum inclination so the wheels do not lift off the ground. When the slope of the vehicle becomes too large on the side where it is lifted, the Slope too steep LED (1) lights up.

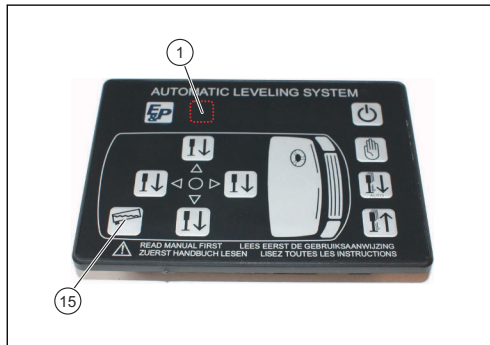

3. Push the *ON / OFF* button (5) to turn the level system OFF



Emergency operation

In the event of a fault or power failure, the system has an emergency actuation function for retracting the supports.

**Warning:**

The emergency retraction may only be carried by trained service personnel.
The vehicle must be secured against rolling away and sagging before any work is carried out under the vehicle.

If a fault occurs when the supports are extended (cannot be retracted via the system), please contact your AL-KO or E&P Service/Customer Center.

E&P Hydraulics

Haverstraat 143, 2153 GD, Nieuw-Vennep, The Netherlands
+31 (0)25 2626151
info@ep-hydraulics.com
www.ep-hydraulics.com

To get to the E&P service centers, use the following link, or scan the shown QR CODE.
https://www.ep-hydraulics.com/de_de/Service/Servicestuetzpunkte



E&P Service/Service points

To access the E&P downloads, use the following link, or scan the shown QR CODE.
https://www.ep-hydraulics.com/de_de/Service/Downloads



E&P Service/Downloads



Attention: The emergency retraction may only be carried out by trained service personnel.

MAINTENANCE

Maintenance Schedule

The system does not have parts that must receive periodic maintenance. Visual checks, functional checks and cleaning must be done during the annual vehicle service. When parts are disassembled, the warranty becomes invalid. If necessary, parts can be replaced or repaired by your E&P Hydraulics dealer/installer.

Preventive maintenance



Caution: Do not clean the system with a high-pressure water cleaner.

Part or adjustment	Frequency	Procedure
Cylinder surfaces and gaskets	Regularly	Make sure that the parts are clean, and do a check for wear, corrosion, oil leakage and damages.
Connection components and screws		
Power unit and hose fittings		
Tank vent		
Hydraulic jacks and foot plates		
Electronic cables and connections		
Hoses, cables and screws		

Permitted cleaning agents

- Soap suds
- Commercially available, surfactant-based cleaning agents.

TROUBLESHOOTING





General troubleshooting procedure







If there are any error messages, make sure that:

- The handbrake is engaged.
- The ignition is set to ON.
- The battery has sufficient voltage.
- The oil level is correct.
- The jacks do not have damages.
- The cables do not have damages.

If this does not solve the problem, there could be something wrong with the drive units. When you think the drive units do not operate correctly, speak to your E&P Hydraulics dealer/installer.

Error descriptions

Symbol	Error message	Description	Possible solution
	<i>Pull parkbrake</i>	The handbrake is not engaged.	Engage the handbrake.
	<i>Vehicle battery empty Charge battery</i>	The battery does not have sufficient power for the leveling system to operate.	Charge the battery.
	<i>Angle of incline too large Use manual operation</i>	The inclination is too large to automatically level the vehicle.	Manually level the vehicle. If the jacks are too short, put blocks below the jacks. Warning: <ul style="list-style-type: none"> ■ One or more wheels could come off the ground. ■ The vehicle could move because of a slippery surface.
	<i>Overheat error Wait for cool down</i>	The pump has operated for too long and is too hot.	Let the pump cool down before you use the leveling system.

Symbol	Error message	Description	Possible solution
	<i>Retract error Jacks not retracted</i>	The jacks could not retract. It is possible that the oil level is insufficient, or that there is a defect in the system.	Speak to your dealer.  Warning: Before you drive the vehicle, make sure that the four jacks are fully retracted. Refer to <i>Retract the jacks</i> .
	<i>Jack down time error No movement felt</i>	The jacks did not correctly touch the ground. It is possible that the jacks sank into the ground, or the oil level is insufficient.	Retract the jacks. Extend the jacks and monitor the movement of the jacks.
	<i>Level movement error Possible jacks too short</i>	The leveling procedure could not be completed, possibly because the jacks are too short.	Manually level the vehicle, move the vehicle to a flatter area, or put blocks below the retracted jacks and do the procedure again.
	<i>Movement time error</i>	The leveling procedure could not be completed. It is possible the jacks sank into the ground, or the oil level is insufficient.	Retract the jacks. Extend the jacks and monitor the movement of the jacks.
	<i>Wrong movement Left-right inverted</i>	The vehicle makes an unexpected movement during the leveling procedure. The cause could be wind, one or more jacks sank into the ground, or someone moved the vehicle.	Do the leveling procedure again.
	<i>Wrong movement Front-rear inverted</i>	The vehicle makes an unexpected movement during the leveling procedure. The cause could be wind, one or more jacks sank into the ground, or someone moved the vehicle.	Do the leveling procedure again.

Error mode

- If the ignition switch is not set to ON, or if the hand brake is not engaged, the leveling system cannot be started.
- The retracting procedure stops if the pump is runs on overpressure for a few seconds. A timer counts up when the pump operates and counts down when the pump does not operate. If this timer gets at a value that is too high, the pump stops so it does not get too hot.

Troubleshooting table

Problem	Possible cause	Possible solution
The hydraulic leveling system does not work.	The ignition of the vehicle is not set to ON.	Set the ignition to ON.
	The handbrake is not engaged.	Engage the handbrake.
The battery low LED is on.	The battery is almost empty.	Start the vehicle to charge the battery.
The LED message retract all jacks does not go out when the supports are retracted (possibly in combination with a failure of the automatic leveling).	The oil level is too low.	Contact your dealer/installer
	The retract the jacks button does not operate correctly.	Contact your dealer/installer
The jacks do not (fully) extend when the pump operates.	The oil level is too low.	Contact your dealer/installer
	The valve or the pump does not operate correctly.	Contact your dealer/installer
	There is no electrical connection between the operation system and the valve.	Contact your dealer/installer



Note: For all other problems, speak to your dealer/installer.

TECHNICAL SPECIFICATIONS

Specifications of the hydraulic pump

Dimensions and mass

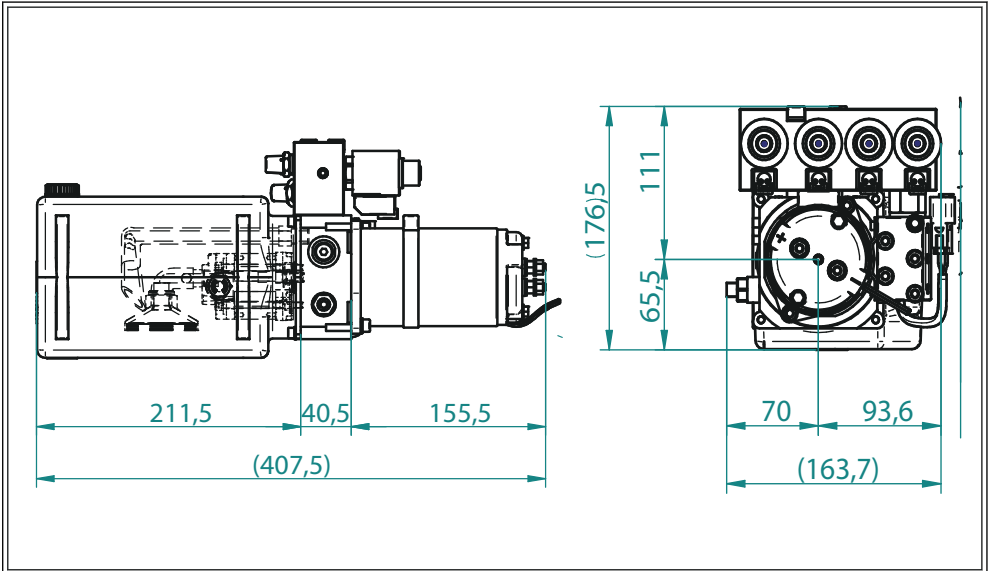

Item	Specification (metric units)	Specification (British units)
Length (X)	407,5 mm	16,04 Zoll
Height (Y)	176,5 mm	6,94 Zoll
Width (Z)	163,7 mm	6,44 Zoll
Mass	6.000 g	13,23 lb

Electrical data

Item	Value
Power supply	12 Vdc

Ambient conditions

Item	Specification (metric units)	Specification (British units)
Temperature	-20°C to +50°C	-4°F to +120°F



by **AL-KO**

E&P HYDRAULICS

Haverstraat 143
2153 GD, Nieuw Vennepe
The Netherlands
+31 (0)25 2626151
info@ep-hydraulics.com
<https://www.ep-hydraulics.com>